

--	--	--	--	--	--	--	--	--	--

Third Semester B.E. Degree Examination, June 2012
Electronics Circuits

Time: 3 hrs.

Max. Marks:100

Note: Answer FIVE full questions, selecting at least TWO questions from each part.

PART – A

- 1 a. Sketch and explain with the circuit, the combination clippers which limit the output between $\pm 5V$. Assume diode voltage is $0.7V$. (08 Marks)
- b. What is Clamping? With neat diagram and waveform, explain the working of negative clamper and also write the condition for stiff clamper. (07 Marks)
- c. Explain Varactor diode with its characteristic curves. (05 Marks)
- 2 a. With circuit diagram, explain base bias amplifier and give the importance of capacitor. (06 Marks)
- b. Explain small signal operation of amplifiers. (04 Marks)
- c. For the circuit given below fig.Q2(c), (i) Calculate the input impedance of the base with $\beta = 100$; (ii) Draw the DC equivalent circuit; (ii) Draw the AC equivalent circuit using T and Π model. (10 Marks)

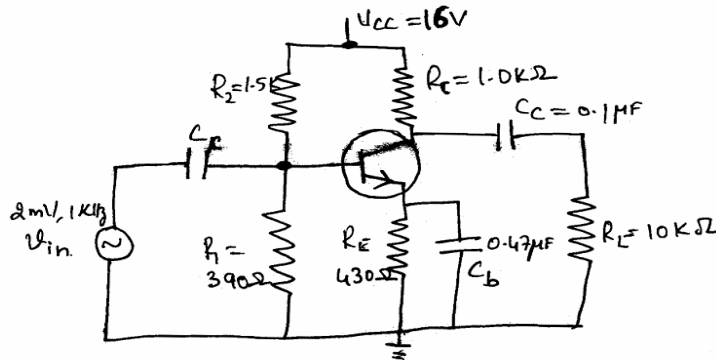

- $R_1 = 390\Omega$
- $R_2 = 1.5k\Omega$
- $R_C = 1k\Omega$
- $R_E = 430\Omega$
- $C_C = 0.1\mu F$
- $C_B = 0.47\mu F$

fig.Q2(c)

- 3 a. What is multistage amplifier? With the neat circuit diagram explain two stage CE amplifier and derive equation for voltage gain. (10 Marks)
- b. For the swamped amplifier shown fig.Q3(b) below, calculate; (i) Input impedance of the base; (ii) The input impedance of the stage; (iii) AC input voltage to the base; (iv) Voltage gain; (v) AC voltage across the load. (10 Marks)

Neglect r_e

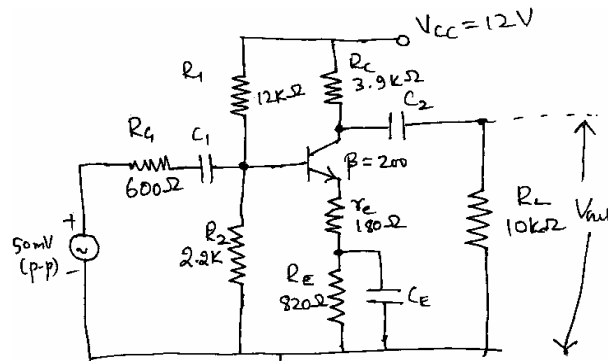

fig.Q3(b)

Important Note : 1. On completing your answers, compulsorily draw diagonal cross lines on the remaining blank pages.
2. Any revealing of identification, appeal to evaluator and /or equations written eg, 42+8 = 50, will be treated as malpractice.

- 4 a. Explain the classification of amplifiers based on their operation. (06 Marks)
 b. Draw the DC load line and AC load line for a VDB amplifier. (05 Marks)
 c. With the circuit diagram explain push pull power amplifier and list the advantages and disadvantages of push pull amplifier. (09 Marks)

PART – B

- 5 a. What is ohmic region of E–MOSFET? With the circuit diagram determine whether the MOSFET is based in the ohmic region. (10 Marks)
 b. The E–MOSFET in the circuit fig.Q5(b) has following parameters $V_{4S(ON)} = 4.5V$, $I_{D(OW)} = 75$ mA and $R_{DS(ON)} = 10\Omega$. Calculate the output voltage. Show the equivalent circuit. (04 Marks)

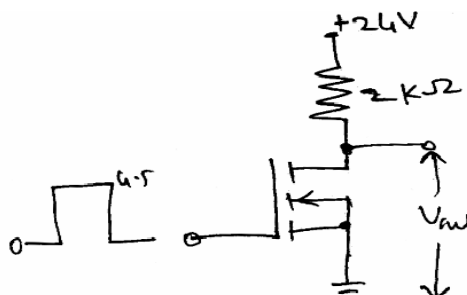

fig.Q5(b)

- c. Discuss in detail CMOS Operation and power consumption. (06 Marks)
- 6 a. Draw the frequency response diagram of an AC amplifier and identify cut off frequency, mid band gain. (04 Marks)
 b. Define DECIBEL power gain, DECIBEL voltage gain. For the cascaded amplifier shown below, calculate the decibel voltage gain of each stage and the overall decibel gain fig.Q6(b). (06 Marks)

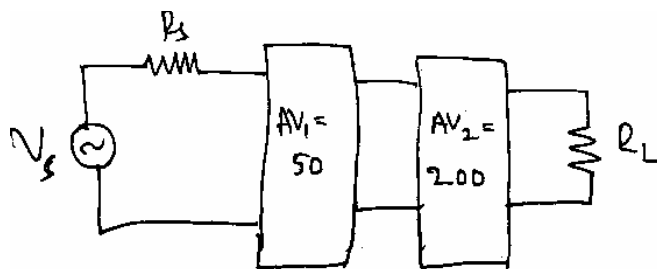

fig.Q6(b)

- c. Explain the various types of negative feed back amplifiers. (10 Marks)
- 7 a. Explain with circuit diagram the inverting Schmitt trigger. Draw the input and output wave form for $R_1 = 90k\Omega$, $R_2 = 10k\Omega$, and $V_{Sat} = \pm 10V$, show the hysteresis curve. (10 Marks)
 b. With the functional block diagram of 555 explain the astable operation. Draw the output wave form across the capacitor. (10 Marks)
- 8 a. Define load regulation and line regulation. (04 Marks)
 b. Draw the circuit diagram of zener and two transistor discrete series regulator and derive output voltage equation. (06 Marks)
 c. What is fold back current? With the circuit diagram explain how fold back current is limited. (06 Marks)
 d. Discuss linear IC voltage regulator. (04 Marks)
